



**YANMAR**

MINI EXCAVATOR

# Vi012-2A



Operating weight

1 245 kg

Engine

3TNV70-WBVB

Tear-out force

5,8 kN

Breakout force

13,9 kN

# Simply the best



## COMPACTNESS

Here's the shape for simple and efficient work in confined spaces. With its extendable undercarriage and its total width of 1 meter, the Vi012-2A is a tenacious worker for narrow spots such as housing foundations, indoor renovation, pipe laying and landscaping.



## ERGONOMY

The use of joysticks on both sides of the seat enables to improve the position of the operator, therefore enhancing his comfort while working.



## YANMAR ENGINE

The YANMAR TNV engine has been designed to combine high power and cleaner emissions. With a power of 9,2 kW, it meets the European Commission (EC) emission standards.



## PERFORMANCE

The attention paid to the quality of the power line ensures excellent performance while the optimal combination of the Vi012-2A excavation strengths and work cycles assures exceptional productivity.



## STABILITY

The Vi012-2A has an operating weight of 1245 kg and the longest undercarriage of its class with 1440 mm. This results in a real improvement of the operator's comfort. He benefits from a smoother drive and increases his productivity.



# COMPACTNESS



## THE Vi012-2A IS A TRUE ZERO TAIL SWING EXCAVATOR:

- + Extended undercarriage: the front part of the upper frame doesn't exceed the width of the crawlers.
- + Retracted undercarriage: the rear of the machine only exceeds 85 mm.
- + Minimum front swing radius with boom swing: 1080 mm
- + Rear swing radius: only 650 mm
- + Width of the retracted undercarriage reduced to 830 mm

## ADVANTAGES FOR THE USER:

- + Easy access in narrow areas and possibility to work along a wall.
- + Machine perfectly adapted for restoration of houses.
- + The Vi0 concept allows the operator to work without paying attention to the rear of the machine: safety and productivity.



## EXTENDABLE UNDERCARRIAGE OF UNIQUE CONCEPTION

- + Reduced clearance between the sliding parts: no soil build-up during the extension of undercarriage.
- + High reliability over a long-term period.
- + The Vi012-2A is extremely stable due to the use of an extended undercarriage and good weight distribution.

## SIMPLE FOLDING EXTENDABLE BLADE

The hinged blade extensions are permanently fixed on the blade. No tools are necessary to change quickly the position. No risk to lose the blade extensions.



# DESIGN



## JOYSTICKS

### IMPROVED ERGONOMICS

The Vi012-2A is equipped with joysticks on both sides of the seat::

- + Improvement of the operator position
- + Comfort enhanced
- + Better control over the machine movements
- + Productivity and precision increased

### SIMPLICITY AND ROBUSTNESS

Yanmar decided to use the same tried and tested joysticks as for its heavier mini-excavators. This well-conceived system offers the following features:

- + Less risk of damages and downtime
- + Longer service life

# STABILITY

The Vi012-2A has an operating weight of 1245 kg and the longest undercarriage of its class with 1440 mm. The machine is more stable with heavy loads or attachments. This is very important for key applications for this type of mini-excavator, such as demolition.



# MAINTENANCE

### EASY ACCESS

A large engine bonnet allows quick access for main components and the left side protection in steel, easily removable allows access to filter.

### BEST COMPONENTS

All Vi012-2A components are designed in order to make it reliable, durable and capable of performing demanding work.



# PERFORMANCE

## ENGINE

The ViO12-2A is equipped with a Yanmar diesel engine 3TNV70 which delivers a power of 9.2 kW and has a torque of 52 Nm. This enables to improve highly the performance of the machine.



## HYDRAULICS

Unlike industry standards for this category of machines, Yanmar is using variable axial pump which adapt the flow and the pressure to the load, allowing smoother operation and improving the comfort of the operator. The pump flow of 2 x 11 l/min and its high working pressure (210 bar) also enable to improve the productivity of the machine and its speed in working motion.

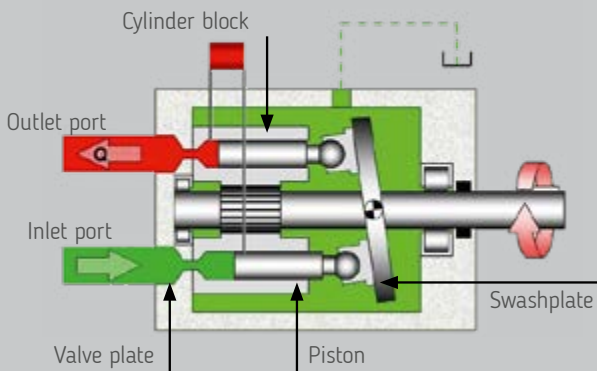

# KINEMATICS

## CUSTOMER BENEFITS

 BETTER PERFORMANCE

 IMPROVED CYCLE-TIMES

 INCREASED PRODUCTIVITY

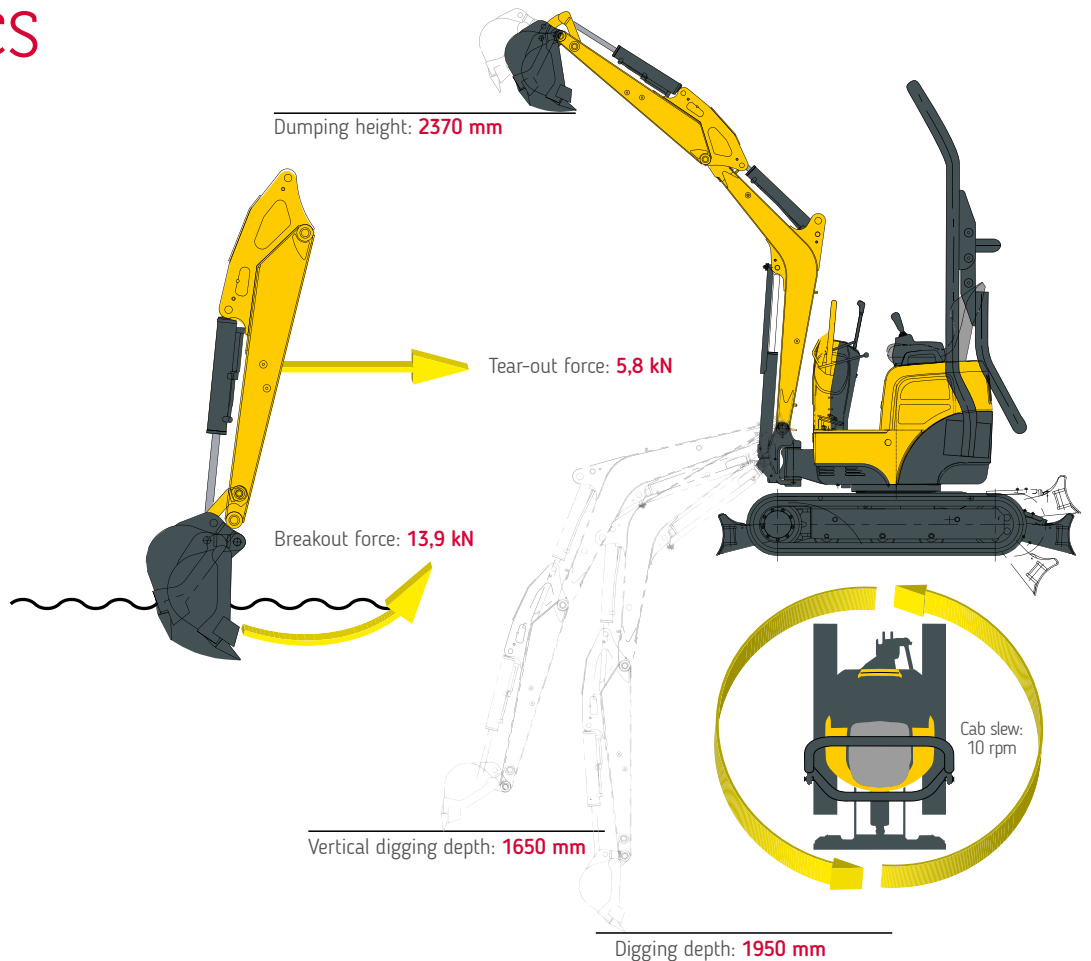

# DIMENSIONS



<b>A</b> Overall length	3040 mm	<b>H</b> Overall blade width	1000 / 830* mm
<b>B</b> Overall height	2250 mm	<b>I</b> Overall blade height	219 mm
<b>C</b> Overall width	1000 / 830* mm	<b>J</b> Blade distance	930 mm
<b>D</b> Length of track on ground	1095 mm	<b>K</b> Max. blade height above the ground	210 mm
<b>E</b> Undercarriage length	1440 mm	<b>L</b> Max. lowering blade depth	230 mm
<b>F</b> Lane	820 / 650 mm	<b>M</b> Minimum ground clearance	140 mm
<b>G</b> Track width	180 mm	<b>M'</b> Ground clearance under counterweight	365 mm

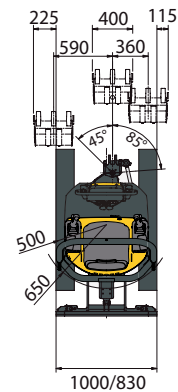
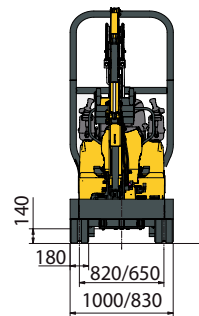
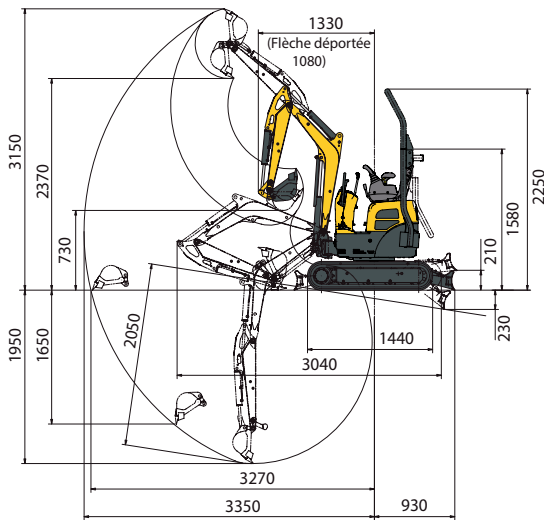

<b>N</b> Max. digging depth - Blade lifted	1950 mm	<b>U</b> Boom swinging base to left	50°
<b>O</b> Max. digging depth - Blade lowered	2050 mm	<b>V</b> Boom swinging base to right	90°
<b>P</b> Max. digging reach on ground	3270 mm	<b>W</b> Arm length	830 mm
<b>Q</b> Max. digging reach	3350 mm	<b>X</b> Minimum front swing radius	1330 mm
<b>R</b> Max vertical wall	1650 mm	<b>Y</b> Minimum front swing radius with boom swing	1080 mm
<b>S</b> Max. dumping height	2370 mm	<b>Z</b> Rear swing radius	650 mm
<b>T</b> Max. cutting height	3150 mm		

\*Undercarriage extended - retracted

Subject to any technical modifications. Dimensions given in mm with standard Yanmar bucket.

# LIFTING FORCE

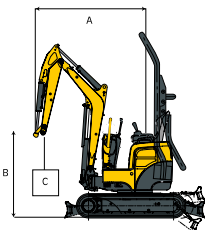

Tipping load, rating over front



Tipping load, rating over side 90°

N : Retracted undercarriage  
W : Extended undercarriage

Blade on ground													Blade above ground														
A	Max.				2,5 m			2 m			1,5 m			A	Max.				2,5 m			2 m			1,5 m		
B	(A=)	W	N	⌋	W	N	⌋	W	N	⌋	W	N	⌋	B	(A=)	W	N	⌋	W	N	⌋	W	N	⌋	W	N	⌋
2,0 m	(2,55)	*185	115	*185	*185	120	*190	*185	145	*185	-	-	-	2,0 m	(2,55)	*185	110	*185	*185	120	*190	*185	145	*185	-	-	-
1,5 m	(2,8)	125	95	230	155	120	*205	*205	165	*205	-	-	-	1,5 m	(2,8)	125	90	160	155	115	*205	205	160	*205	-	-	-
1,0 m	(2,85)	115	90	*230	145	115	*240	200	160	*270	*380	255	*370	1,0 m	(2,85)	115	85	145	145	110	180	200	155	*265	380	245	*365
0,5 m	(2,9)	110	85	*245	145	100	*270	195	150	*345	305	210	*550	0,5 m	(2,9)	110	80	130	145	100	170	195	145	230	305	200	355
0 m	(2,8)	115	85	*260	140	100	*305	185	140	*385	275	205	*600	0 m	(2,8)	115	80	140	135	100	175	185	140	230	270	200	335
-0,5 m	(2,7)	125	90	*280	145	105	*305	180	135	395	260	210	615	-0,5 m	(2,7)	125	90	155	140	100	165	175	130	215	260	200	330

[ The data contained in these tables represent the lifting capacity in accordance with ISO standard 10567. They correspond to 75% of the maximum static tipping load or 87% of the hydraulic lifting power. Datas marked \* are the hydraulic limits of the lifting power. ]

# TECHNICAL SPECIFICATIONS

## [ WEIGHT +/- 2% (EN STANDARD) ]

	Weight	Ground pressure
Operating weight (rubber crawlers)	1245 kg	0,28 kg/cm <sup>2</sup>
Transport weight (rubber crawlers)	1170 kg	0,26 kg/cm <sup>2</sup>

## [ ENGINE ]

Type	3TNV70-WBVB
Fuel	Diesel
Net power	9,2 kW / 12,5 HP / 2 000 rpm
Gross power	9,3 kW / 12,6 HP / 2 000 rpm
Displacement	854 cm <sup>3</sup>
Maximum torque	48,1 - 52 Nm / 1 500 rpm
Cooling	Liquid
Starter	12V - 1.1 kW
Battery	12V - 36 Ah
Alternator	14V - 8.5A

## [ HYDRAULIC SYSTEM ]

Maximum pressure	210 bar
1 double piston pump with variable flow	2 x 11 l/min
1 gear pump	6 l.min <sup>-1</sup>

PTO	Theoretical data at 2000 rpm	
	Pressure (bar)	Oil flow (L.min <sup>-1</sup> )
2 ways	0-210	22 - 13
1 way	0-210	22 - 13



Oil flow decreases as the pressure increases

## [ PERFORMANCE ]

Travel speed	2,1 - 4 km/h
Rotation speed	10 rpm
Tear-out force	5,8 kN
Breakout force	13,9 kN
Grade ability	25°
Noise level (2000/14/CE & 2005/88/CE)	88 dBA

## [ UNDERCARRIAGE ]

Number of top rollers	1
Number of bottom rollers	3

## [ CAPACITIES ]

Fuel tank	12 l
Coolant	2,5 l
Engine oil	2,8 l
Hydraulic circuit	14,3 l
Hydraulic tank	7,4 l

## MAINTENANCE FREQUENCY

[ Change engine oil and filter: 50 h (1<sup>st</sup>) / 500 h (2<sup>nd</sup>) ] [ Change fuel filter: 250 h ] [ Change hydraulic oil filter: 50 h (1<sup>st</sup>) / 500 h (2<sup>nd</sup>) ]  
 [ Change hydraulic oil filter: 1000 h ] [ Change cooling fluid: 2000 h ]



**YANMAR**



Yanmar Construction Equipment Europe  
25, rue de la Tambourine, 52100 SAINT-DIZIER  
France

[ycee-contact@yanmar.com](mailto:ycee-contact@yanmar.com)

[www.yanmarconstruction.eu](http://www.yanmarconstruction.eu)

Non contractual pictures - Printed in France - The manufacturer reserves the right to modify the information in this catalogue without notice. For further information, please contact your authorized Yanmar Construction Equipment dealer.

GB\_Vi012-2A\_0318